

# K-Sim<sup>®</sup> Engine



KONGSBERG

KONGSBERG Engine Room Simulators

## K-Sim Engine DE AC/AC Cruise Vessel DE22-III

The K-Sim Engine DE22 AC/AC Cruise DE 22-III model is based on a large cruise vessel with two synchronous propulsion motors, each rated 14MW. Each propulsion motor has two separate three phase winding which enables “half motor” operation. The vessel is fitted with two direct coupled fixed pitch propellers.

The electrical power plant consists of a 6.6kV system, fed by 4 medium speed diesel generators each rated 13,9 MVA. and two 440V high speed diesel emergency generators each rated 750 MVA.

The control and automation systems include sophisticated power management, pump control and propulsion control systems. The steam plant includes two large oil fired boilers and feed water system. Control room operator panels as well as bridge and steering panels are included.

### Training objectives

The K-Sim Engine DE22 AC/AC Cruise DE 22-III model model is designed to be a valuable tool in the basic and advanced training of marine engineers. The training objectives are to train junior engineers in basic engine room operations, senior engineers in emergency operations and trouble shooting, and to train senior and chief engineers in optimal operation, fuel economy and energy conservation. This is achieved by controlled training, leading to better understanding of the total plant operation, as a result of realistic simulation of a real engine room.

### Compliant with industry requirements

KONGSBERG's simulator models exceed requirements in the STCW convention, Regulation 1/12 and fulfill DNV's standard DNV-ST-0033 for Maritime Simulator Systems.



### KONGSBERG ENGINE ROOM SIMULATORS

Our range of K-SIM Engine Room Simulators provide realistic, hands-on experience in a ship-like environment. Systems include vital components, such as main engine remote control, engine-room local panels, controllers, engine telegraph, alarm systems, power supply switchboards, engine sounds etc.

We have an extensive model library of different propulsion plants and engines types.

Our library includes models of diesel engines such as MAN B&W, Wärtsilä, Sulzer, Pielstick, MaK and MTU. We have Dual Fuel LNG engines & Methanol engine as well as gas turbine, diesel-electric, water jet and steam propulsion plants.

Our systems can be easily networked with our full ship's bridge simulator for total ship training.

## Model Features and Details

Diesel generators	4 × 6.6 kV / 13.9 MVA
Diesel generator speed	514 RPM
Fuel consumption	188g/kWh at MCR
Emergency generators	2 × 440V/750kVA
Fuel consumption	228g/kWh at MCR
Propulsion motors	2.2kV / 14MW
Bow thrusters	2 × 6.6kV / 1700 kW
Stern thrusters	2 × 6.6kV / 1400 kW
Vessel length overall	277,00 m
Propeller speed	145 RPM
No. of rudders	2

Length overall	261 m
Breadth moulded	33,6 m
Draught	7,95 m
Displacement	12000 ton
Tonnage	77000 GRT
Speed	18,5 knots

## Model Main Specifications

High fidelity engine room systems include:

- Sea & LT/HT fresh water systems, incl. FW generators
- Electrical Power plant, incl. 6.6kV, 440V & 220V AC/DC switchboards
- Start and service air compressors
- Steam Plant
- Diesel and heavy fuel oil systems, incl. bunker, settling and service tanks, separators
- Fuel oil supply systems, incl. viscometers
- Lubricating oil systems, incl. LO purifier
- Stern tube systems
- Steering gear/autopilot systems, incl. double acting IMO type steering gear Autopilot
- Propulsion control system, incl. Bridge, ECR and local control
- Propulsion power drive system, incl. Transformers, freq. converters and excitation
- Propulsion motor cooling system, incl. Sea & FW system
- Main bilge system
- Bilge & sludge system, incl. Bilge separator
- Ballast system, incl. Heeling system
- Fire main & sprinkler system

Note: Specifications subject to change without notice

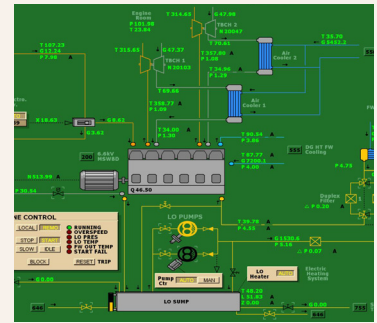

Diesel Generator

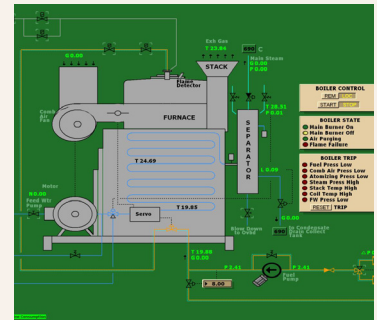

Auxiliary Boiler

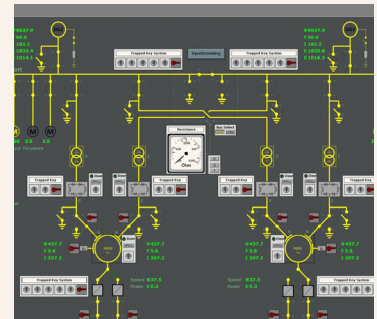

High Voltage Switchboard



CCTV Funnel